

DIRECT GAS FIRED AIR MAKE-UP UNITS TYPICAL ARRANGEMENT

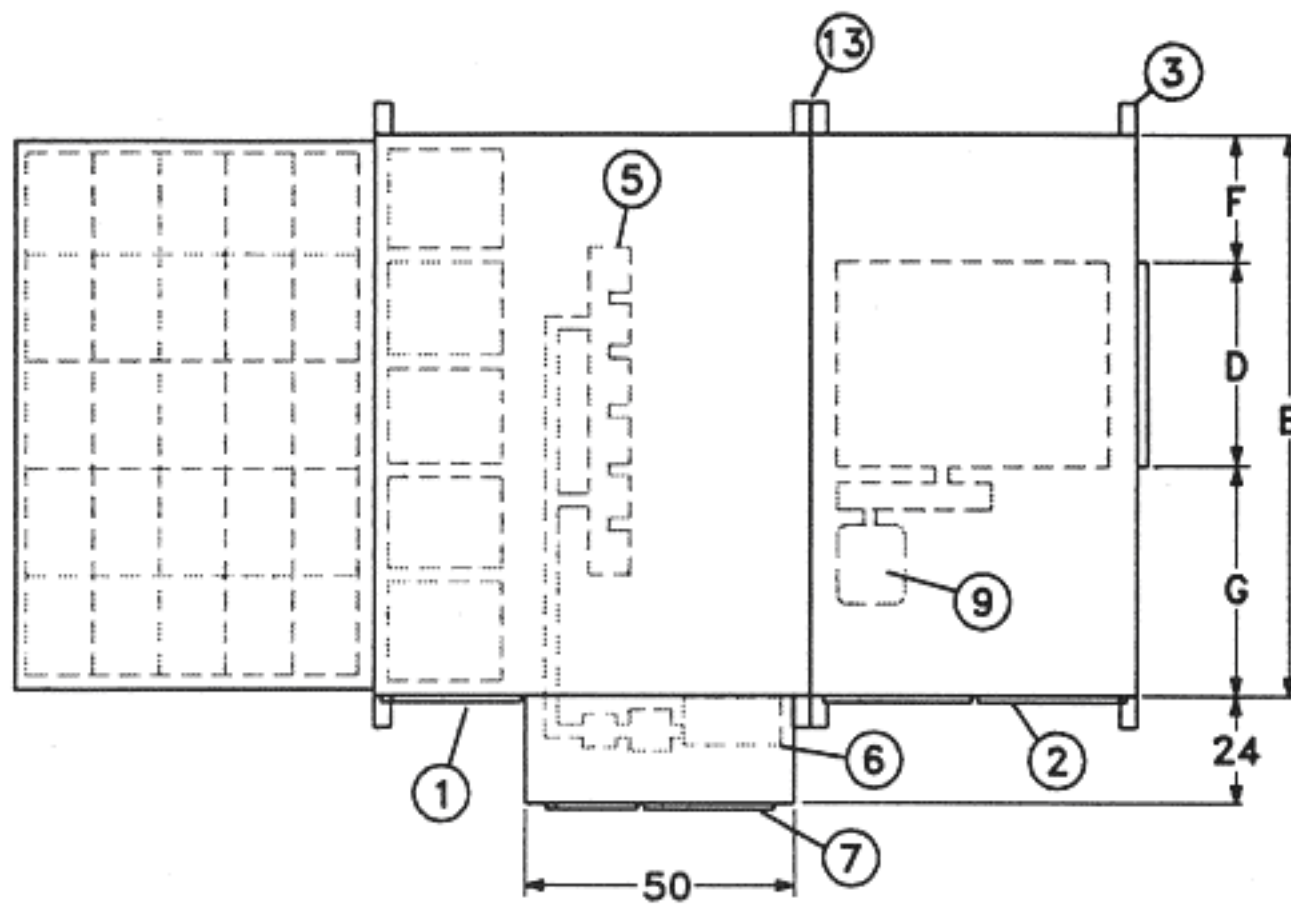

PLAN VIEW

Components:

1. FILTER ACCESS DOOR
2. FAN & MOTOR ACCESS DOOR
3. LIFTING POINT
4. INLET COWL & BIRDSCREEN
5. DIRECT GAS FIRED BURNER
6. CONTROL PANEL
7. ENCLOSURE ACCESS DOORS
8. INSPECTION PORT
9. FAN MOTOR
10. ALTERNATE DISCHARGE
11. WASHABLE FILTERS (STD.)
12. STRUCTURAL STEEL BASE
13. UNIT SPLIT FOR SHIPPING.

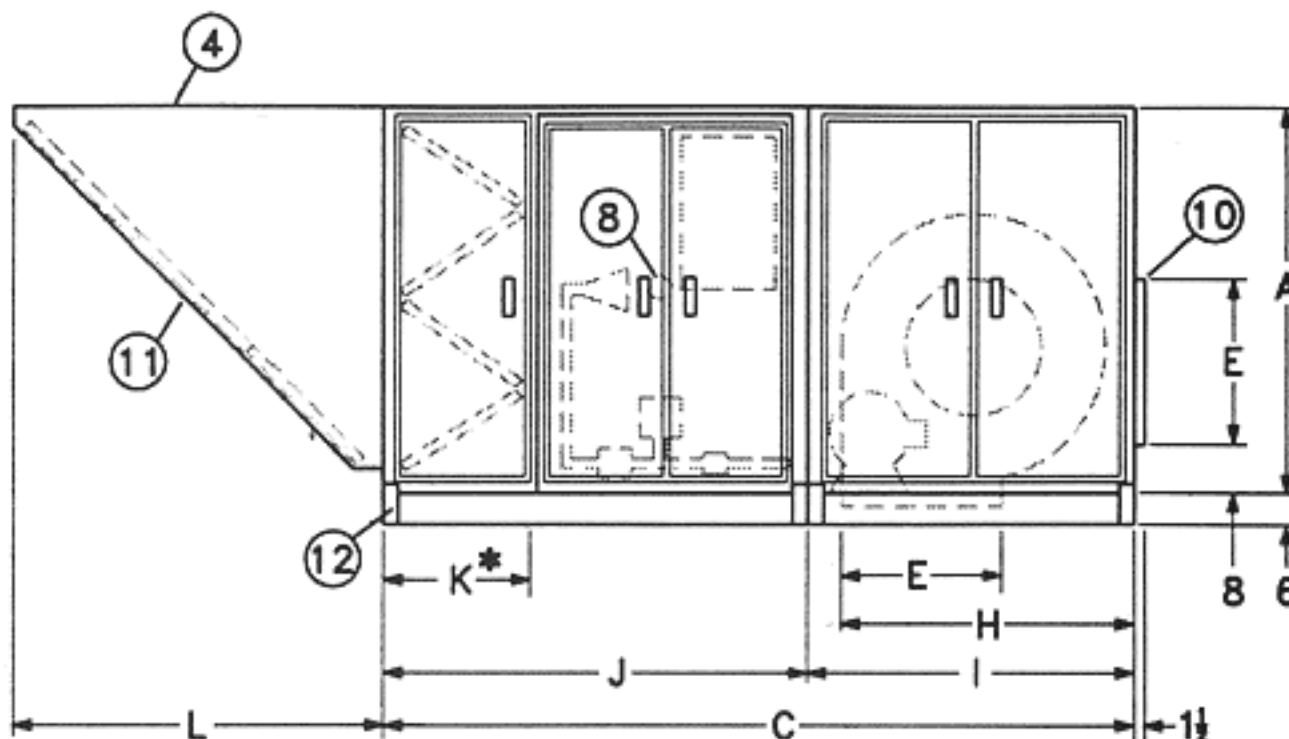

ELEVATION VIEW

Notes:

1. ALL DIMENSIONS ARE IN INCHES AND SUBJECT TO MANUFACTURING TOLERANCES.
- *2. STANDARD WASHABLE FILTERS MOUNTED IN INLET HOOD, USE "K" DIMENSION FOR OPTIONAL FILTER SECTION.
3. UNIT WEIGHTS ARE APPROXIMATE.

Outdoor Horizontal Unit Dimensions

Model	Dimensions															No. & Size of Filters	Unit Weight (Lbs.)	
	A	B	C	D	E	F	G	D ₁	E ₁	F ₁	G ₁	H	I	J	K			L
136	90	110	164	48	39	22	40	50	41	22	38	74	80	84	30	93	25-20x25x2	7500
140	90	121	170	54	41	26	41	55	45	26	40	81	86	84	30	101	30-20x25x2	7900
144	100	129	176	61	44	24	44	60	50	24	45	89	95	81	27	130	40-20x25x2	10400
148	108	154	185	66	50	34	54	67	55	34	53	98	104	81	27	123	48-20x25x2	10600

Note: D, E, F, G Dimensions for Forward Curved Fan Units / D₁, E₁, F₁, G₁ Dimensions for Backward Inclined Fan Units

ALL DIMENSIONS ARE TYPICAL FOR STANDARD CONFIGURATIONS. DUE TO CUSTOM MANUFACTURING AND SELECTED OPTIONS, DIMENSIONS MAY CHANGE, CONTACT SALES REPRESENTATIVE FOR DESIGN VARIATIONS.